

EVOLVE

INSTRUCTION MANUAL SHOULDER PRESS

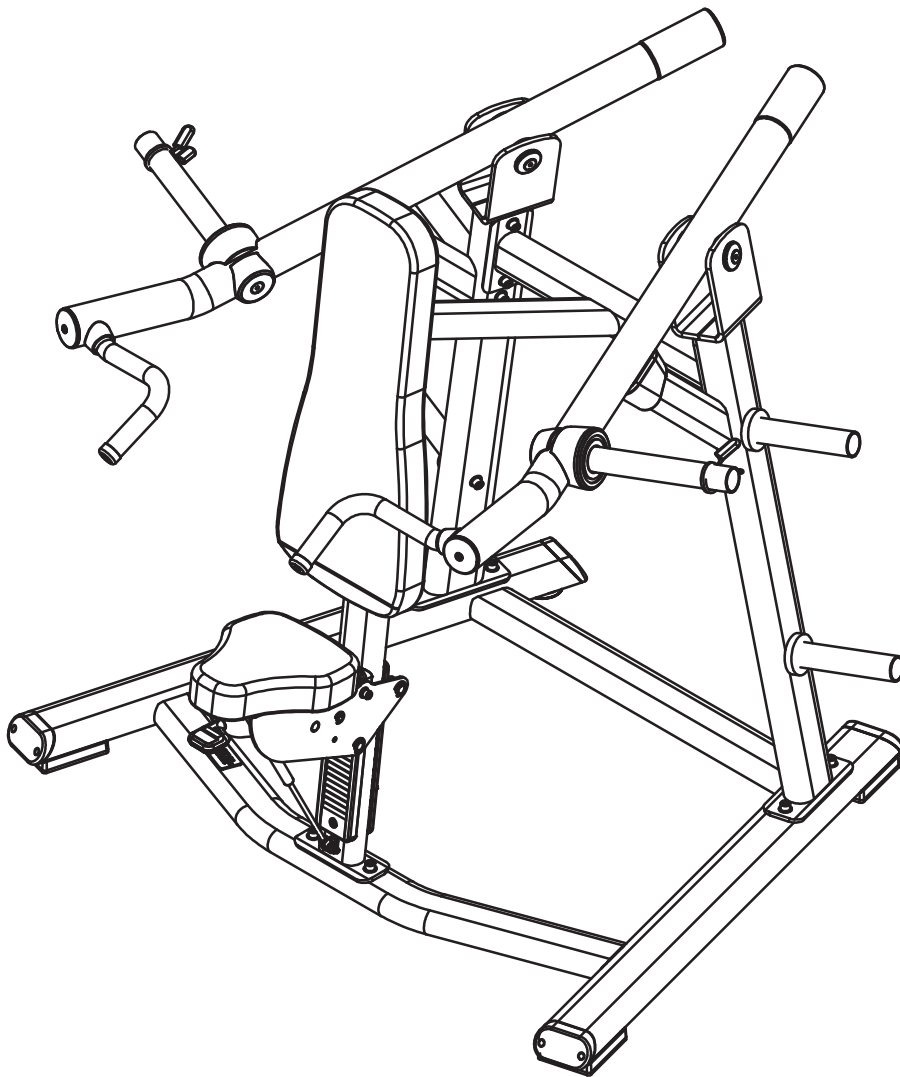

**MAKE SURE YOU HAVE THE
MOST UP TO DATE. THIS IS:**

Version A



TOOLS REQUIRED

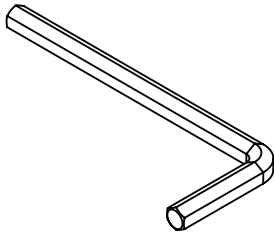

Allen Key

(1x) 4 mm
(1x) 6 mm
(1x) 8 mm
(1x) 10 mm

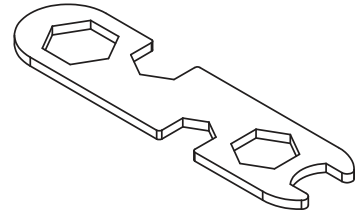

Wrench

(1x) 13 mm

HARDWARE

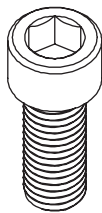

Socket Head Bolt

(4x) M10*30
(16x) M12*30

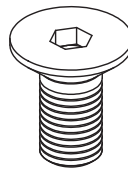

Flat Head Bolt

(2x) M12*35

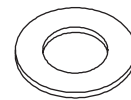

Flat Washer

(4x) M10
(16x) M12

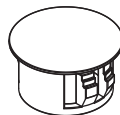

Tube Plug

(2x) D15



BEFORE YOU BEGIN



1. Verify that all components and hardware are included and undamaged. Report any issues immediately.
2. Ensure that you have all the necessary tools before starting the installation.
3. Do **NOT** fully tighten bolts during assembly unless instructed. This helps to ensure proper alignment of all parts.



Access Warranty Information Here



1

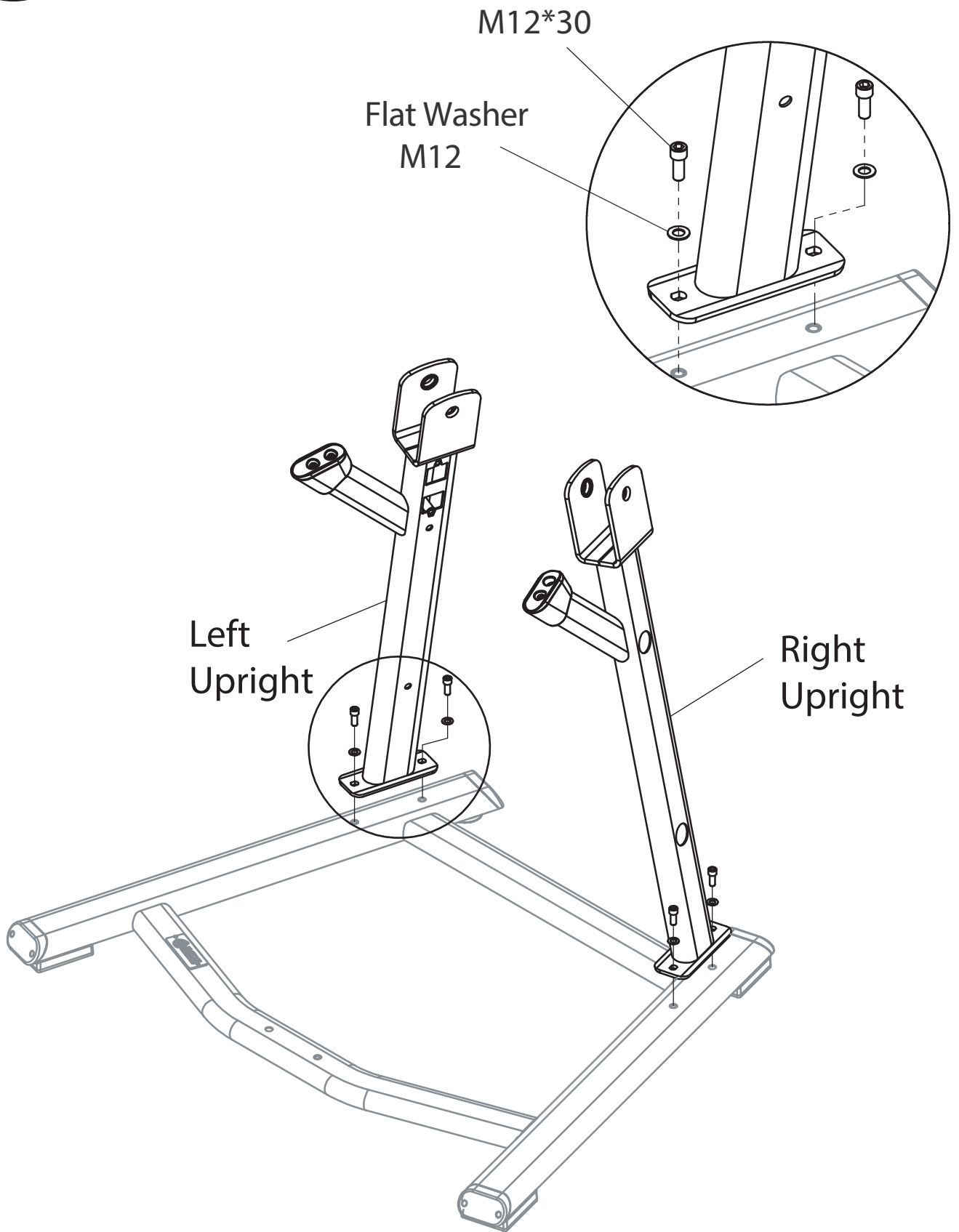

2

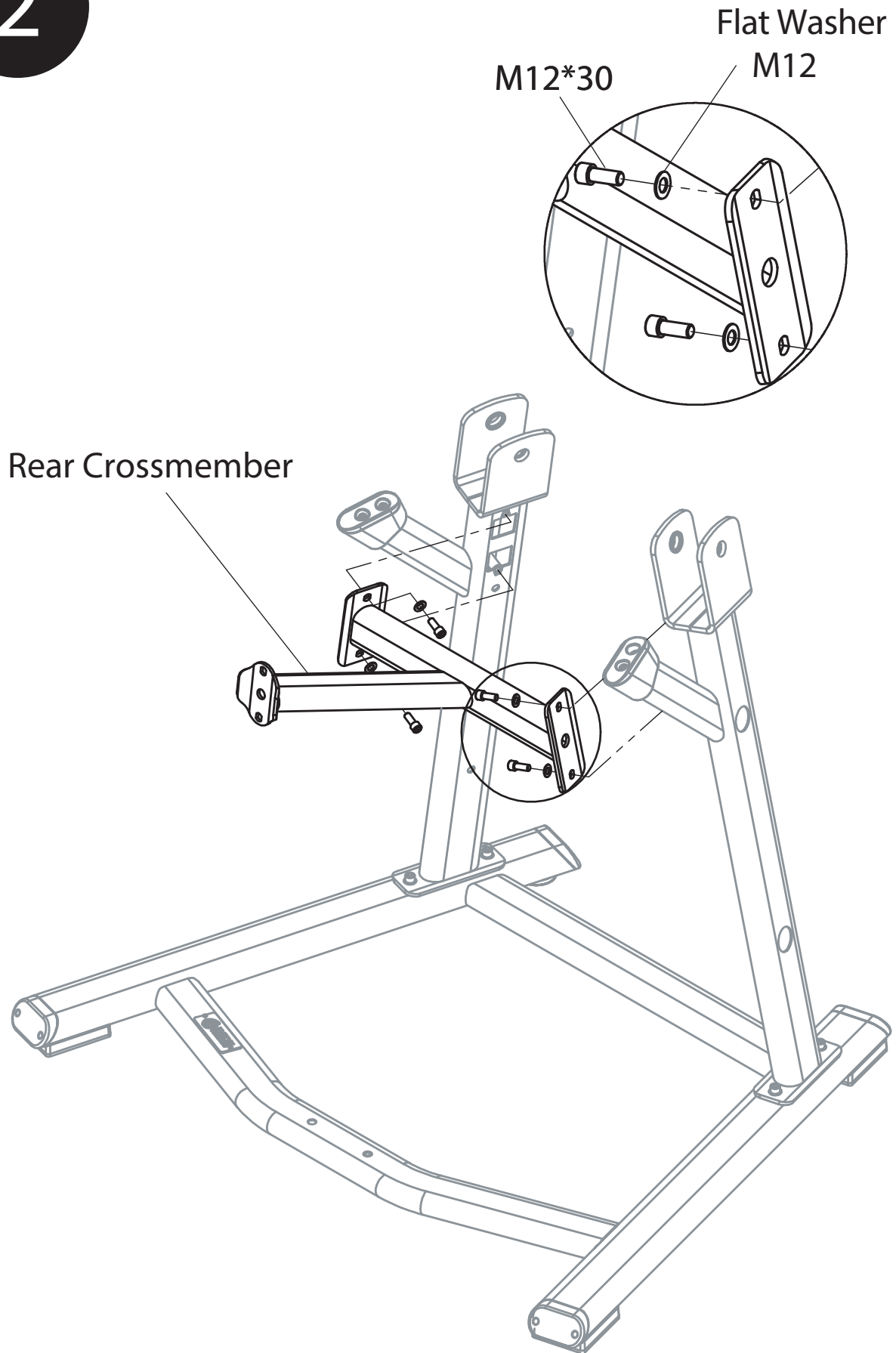

3

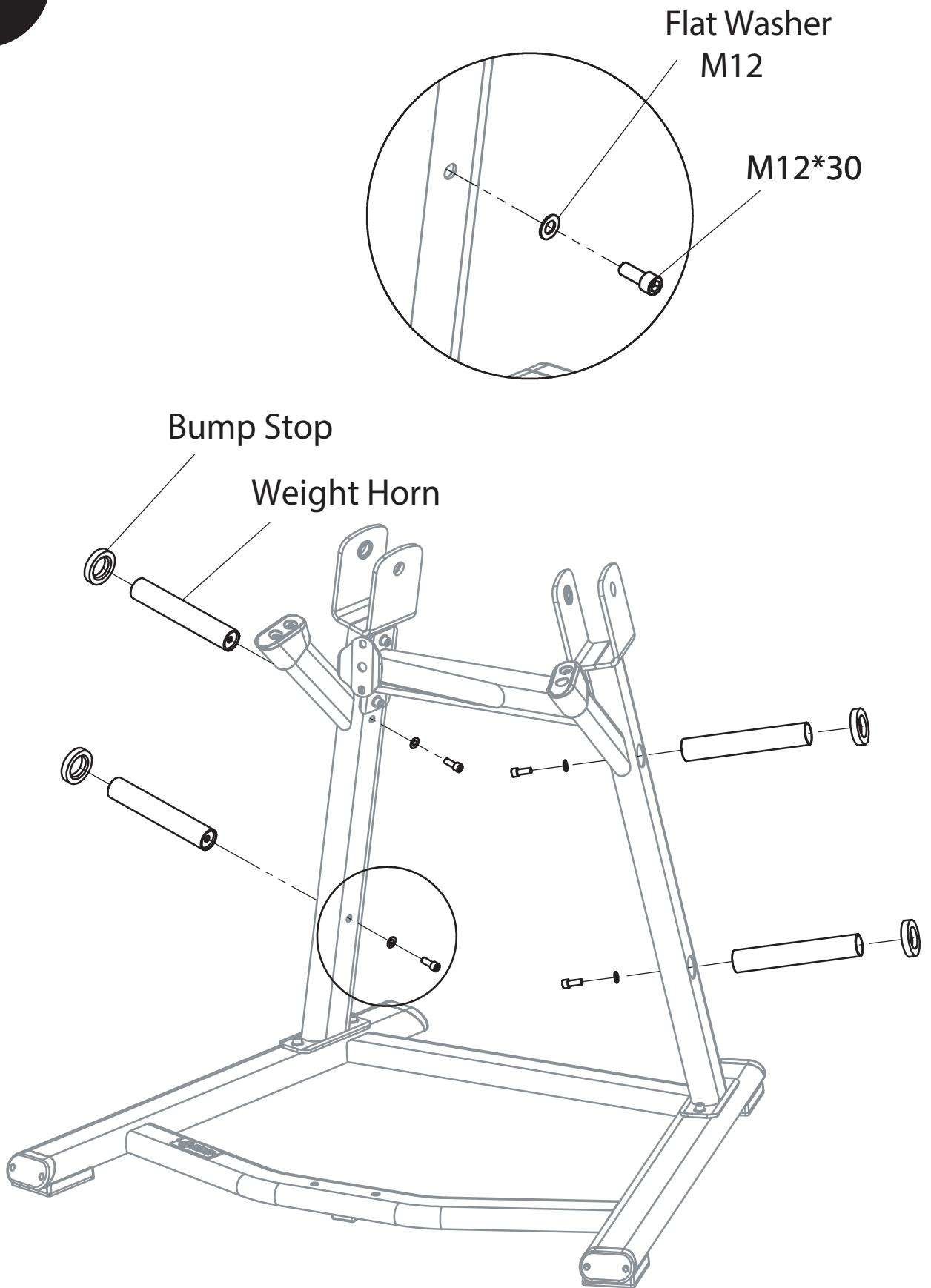

4

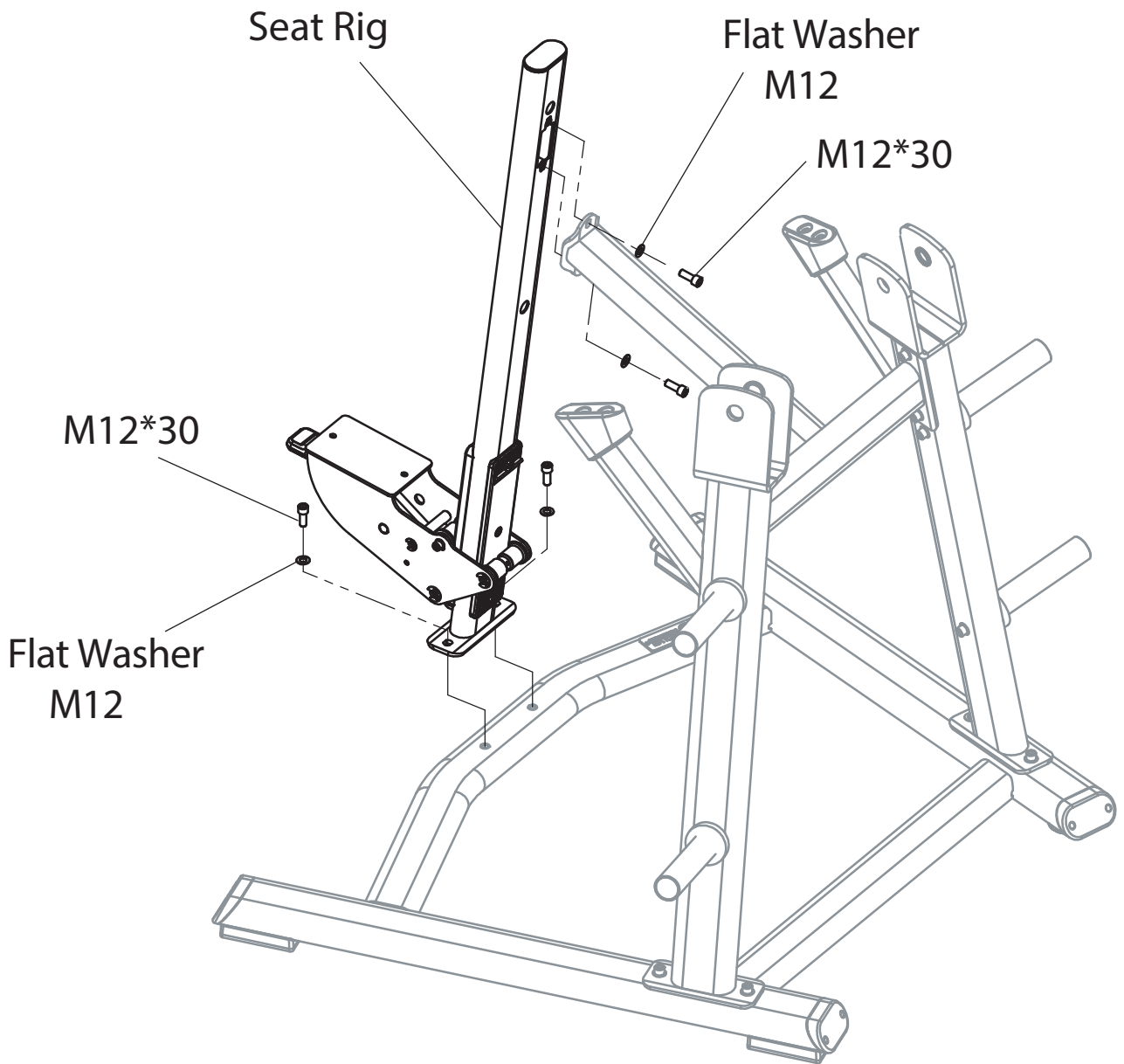

5

UNINSTALL

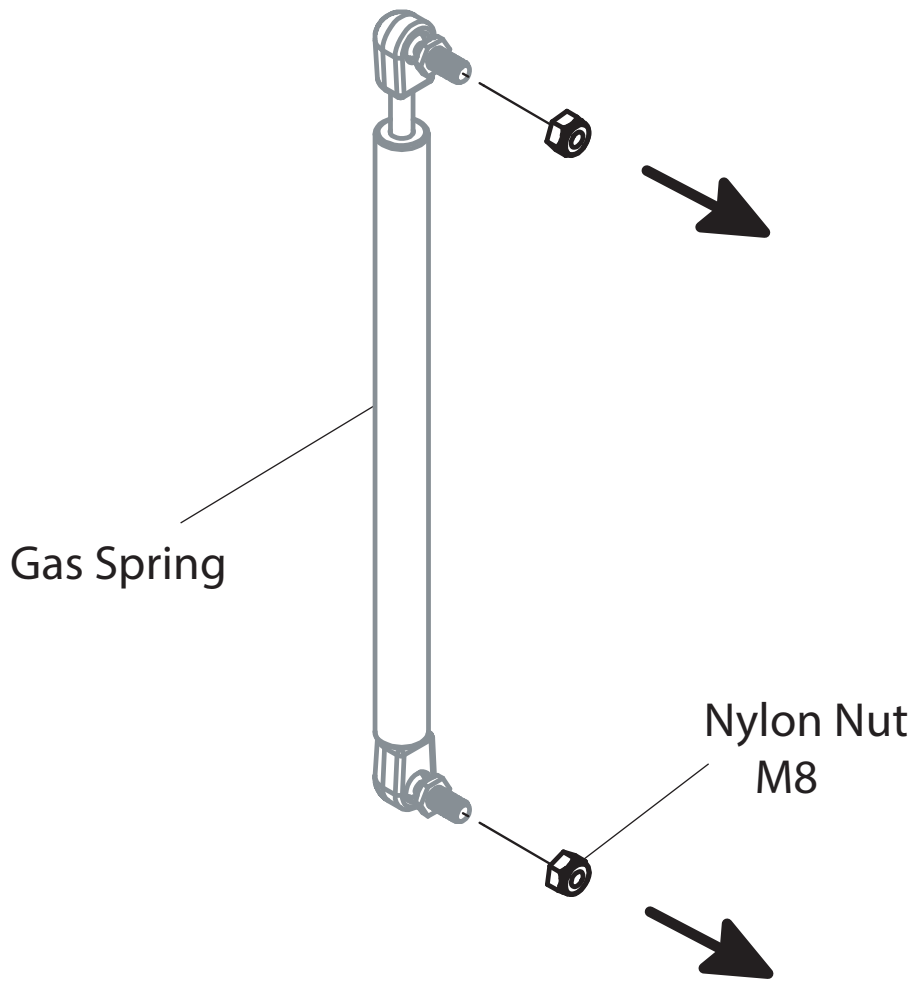

6

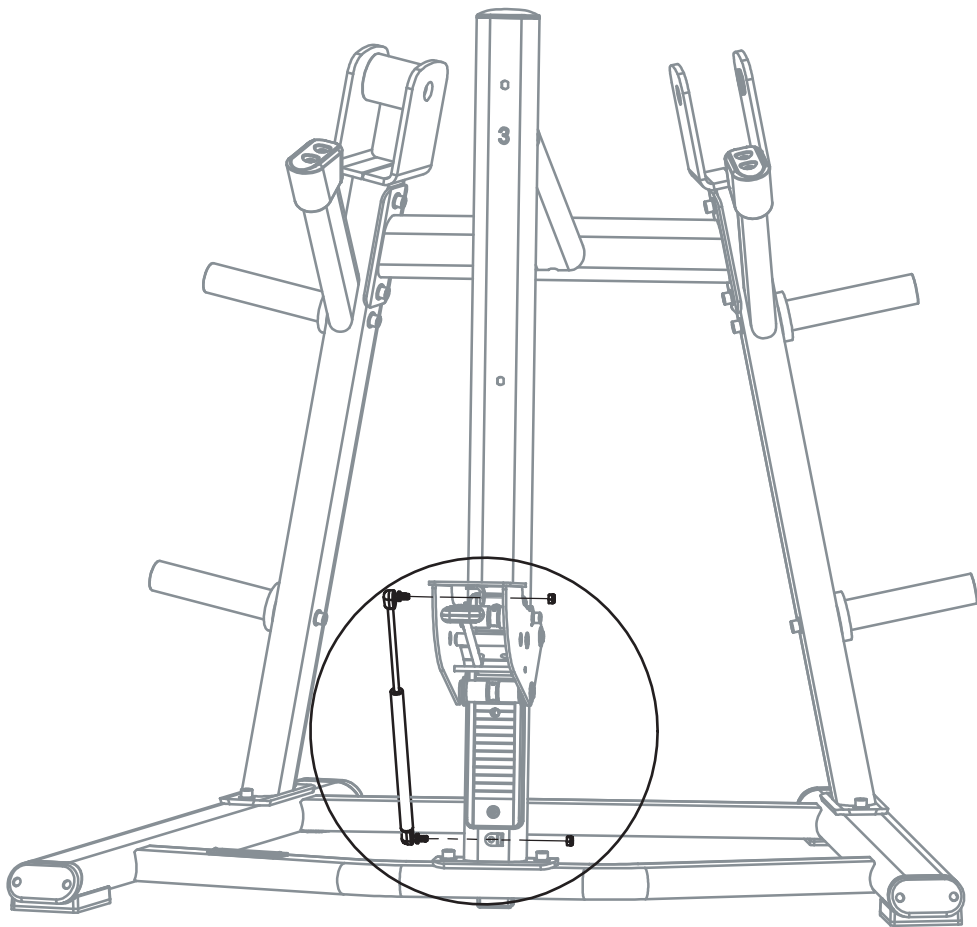
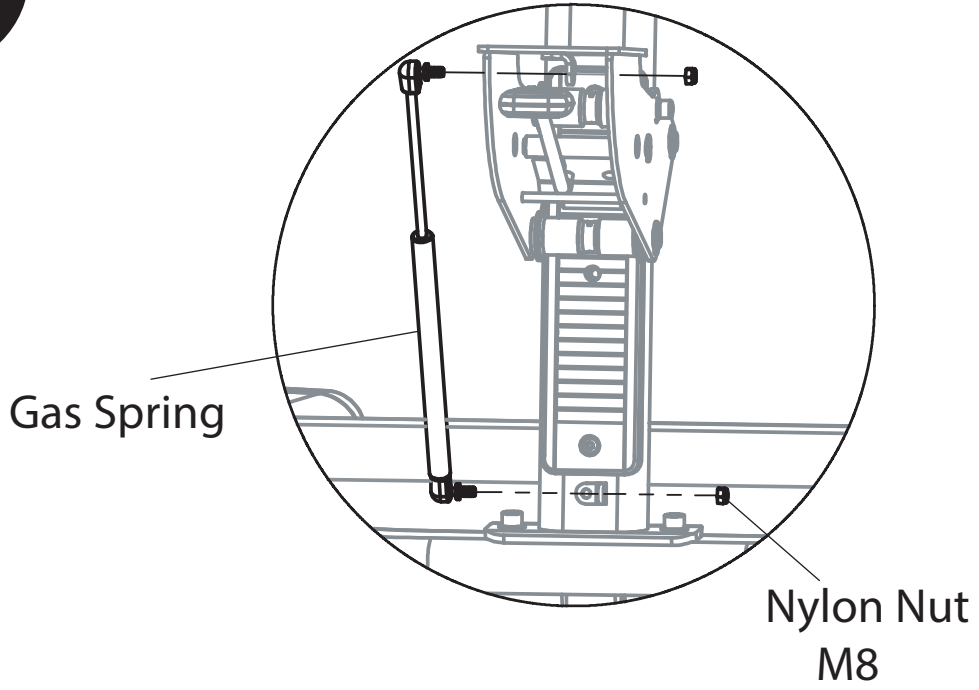

7

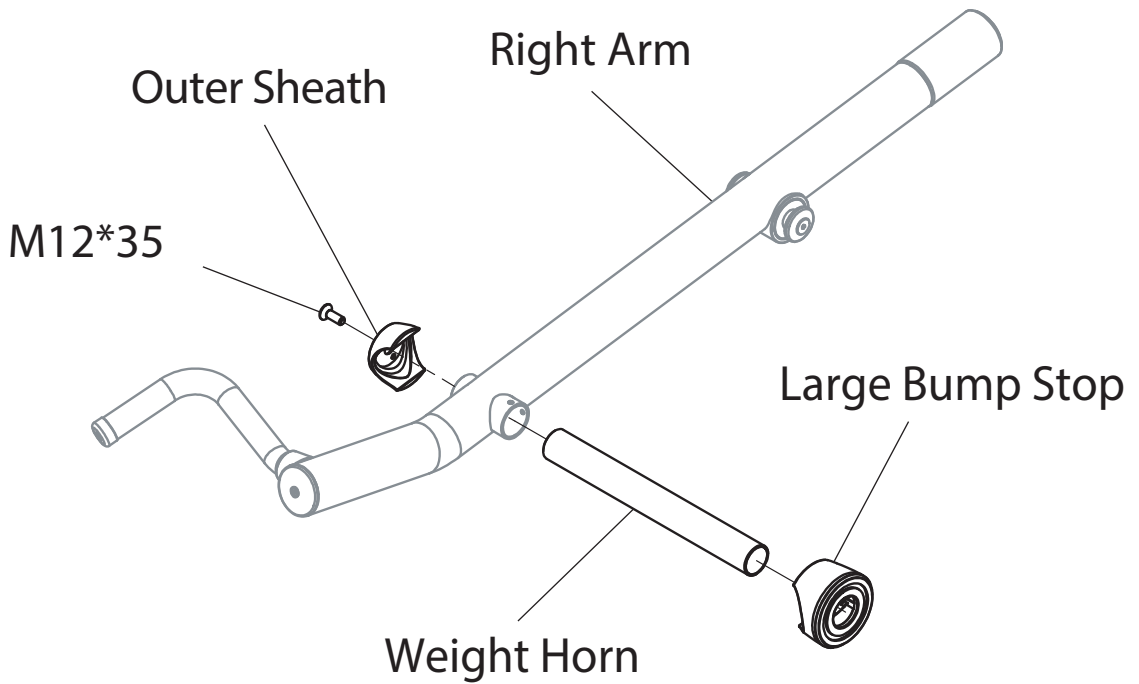
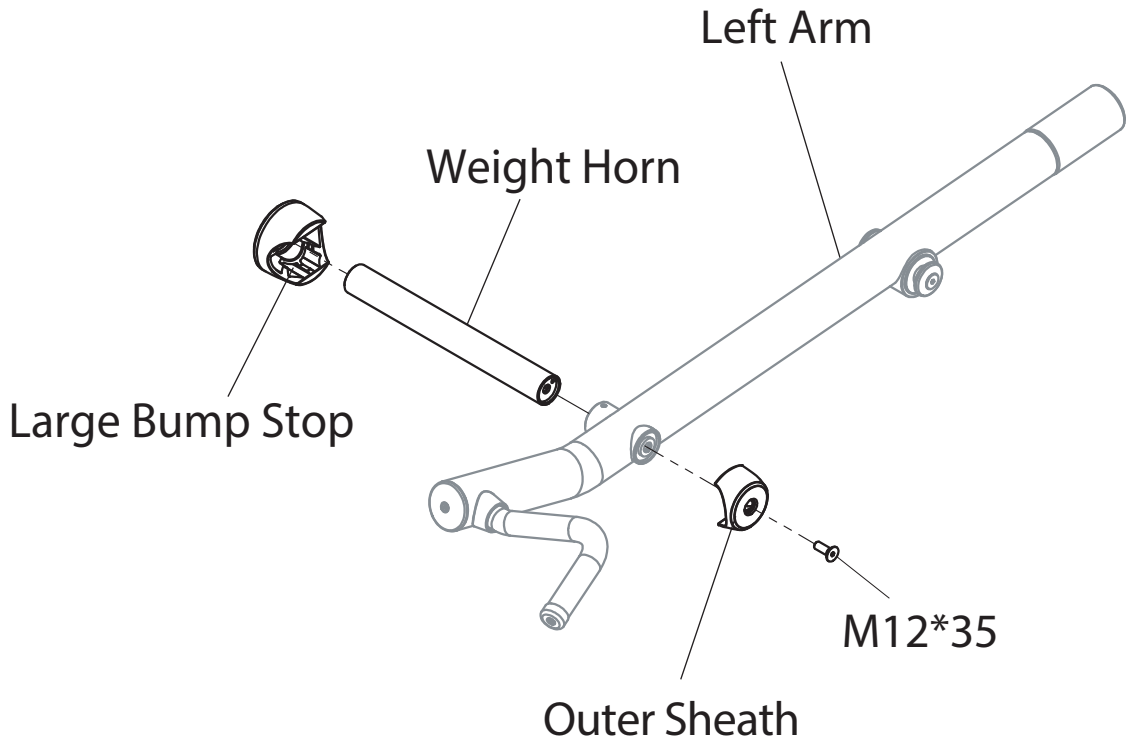

8

UNINSTALL

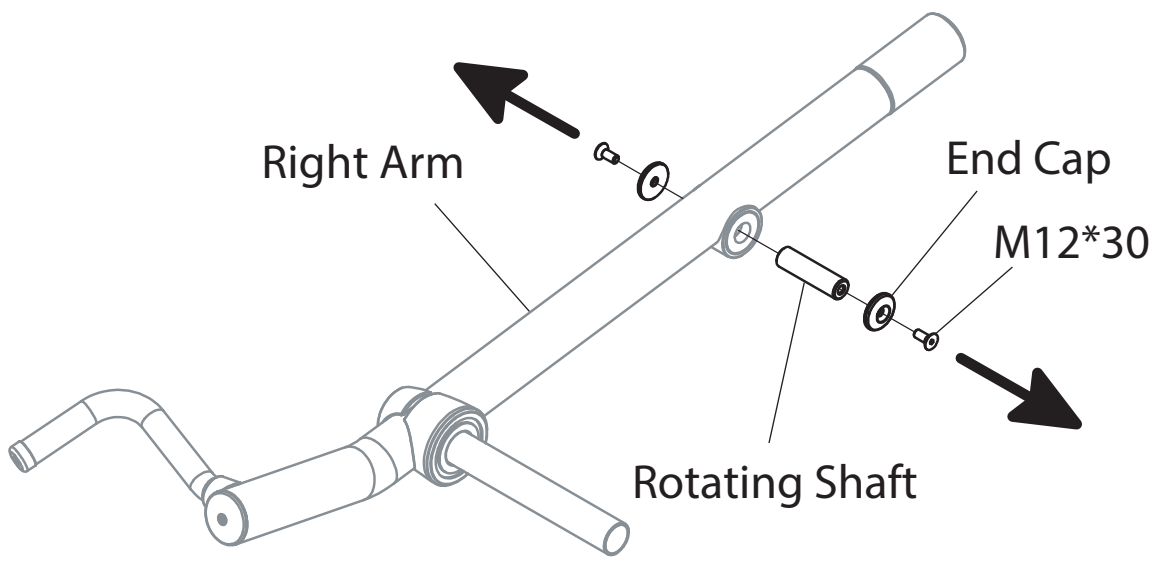
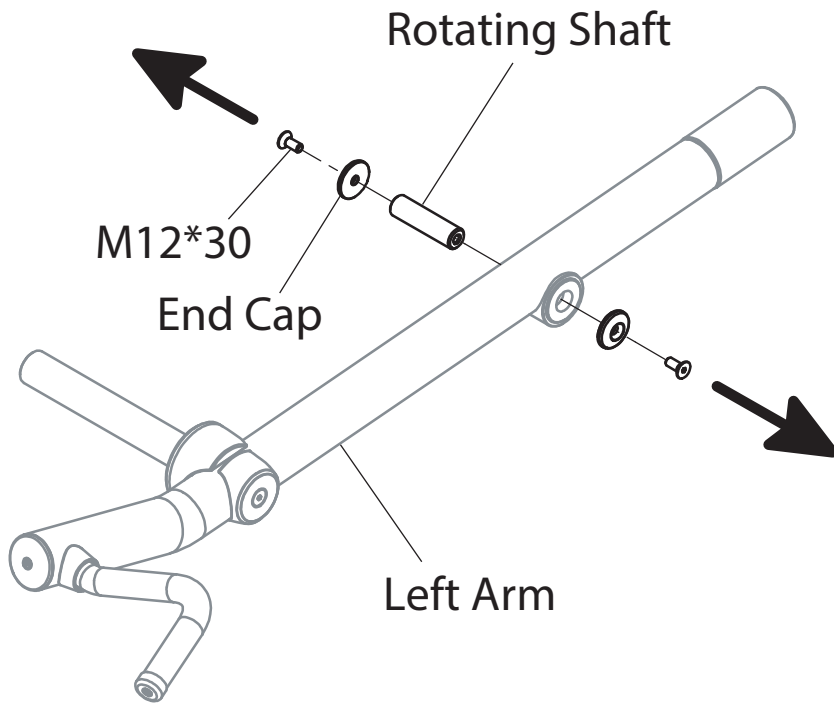

9

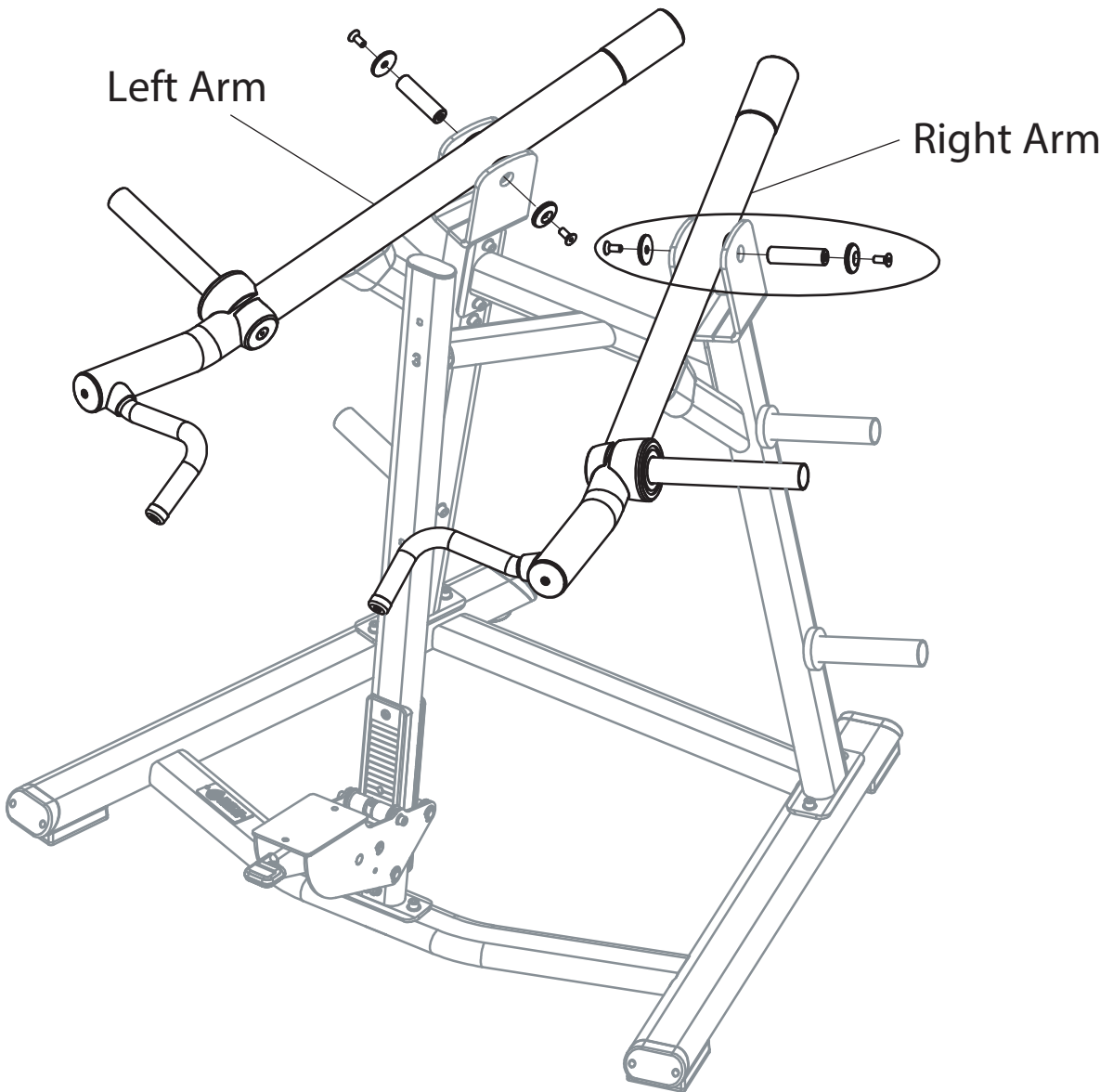
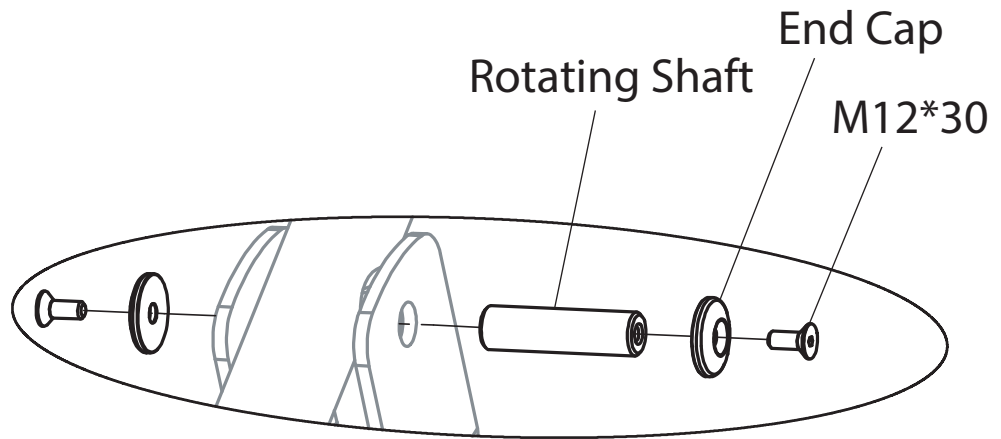

10

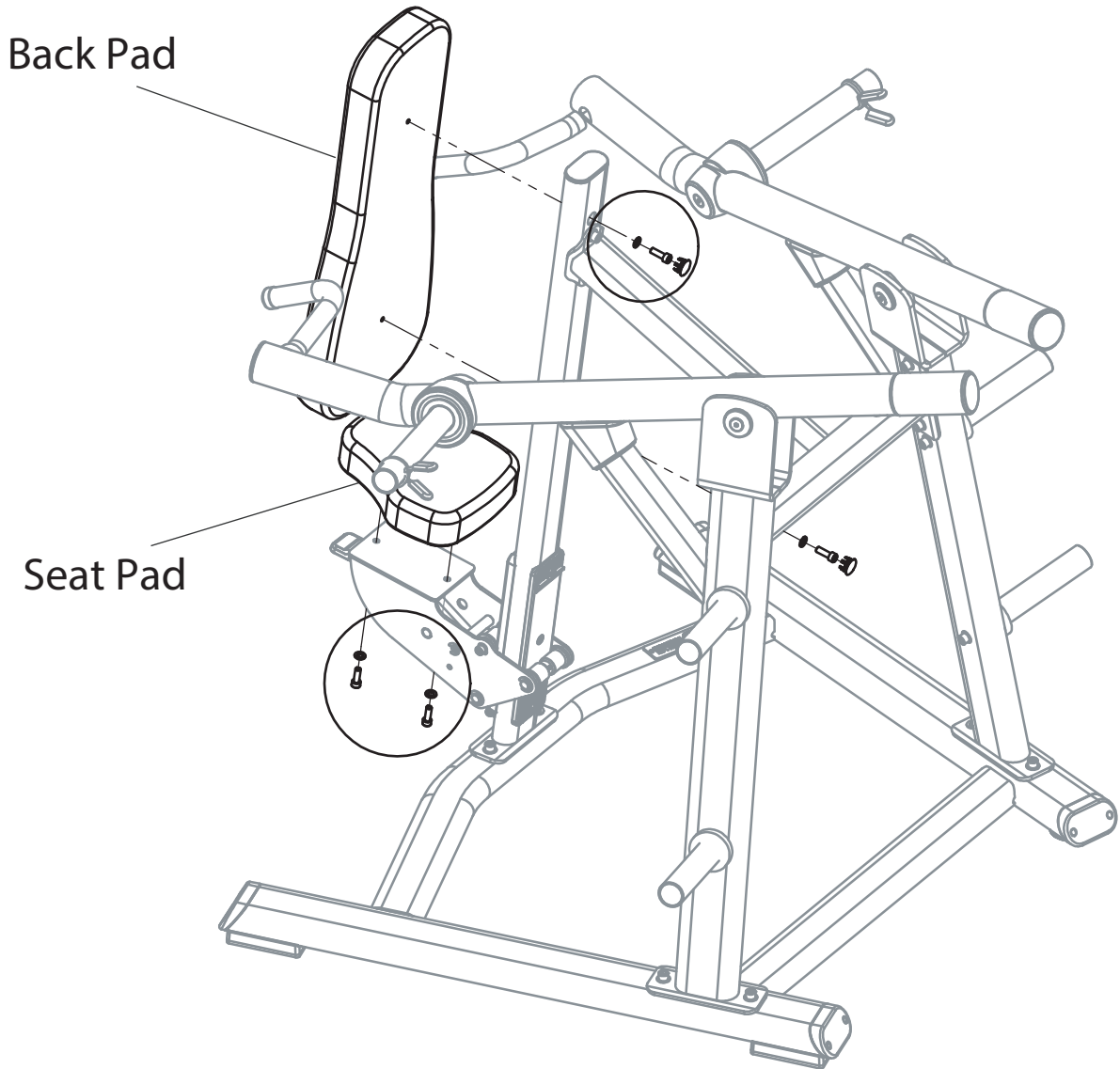
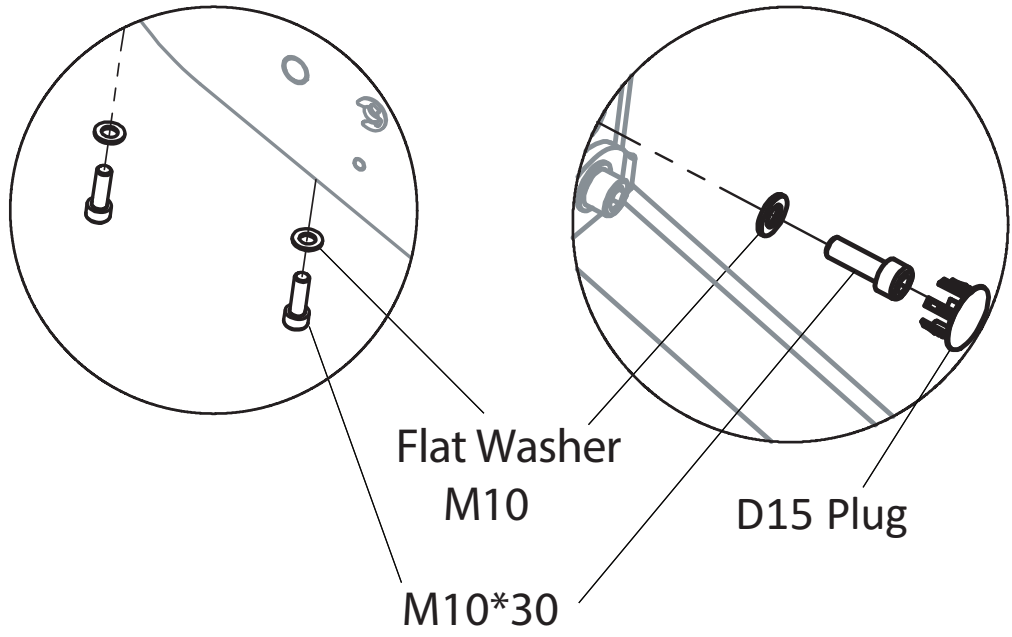

POST INSTALLATION

1. Tighten all hardware prior to testing the functionality of the machine.
2. Do **NOT** use if any components are damaged or if the machine does not function as intended.
3. Report any damage immediately to your local rep.

MAINTENANCE

1. **LEATHER** should be cleaned regularly to prolong the longevity of the fabric.
2. **LARGE BUMP STOP** from step seven may need periodic tightening with 4mm allen key.

